

**R506.2.1 Fill.** Fill material shall be free of vegetation and foreign material. The fill shall be compacted to ensure uniform support of the slab, and except where *approved*, the fill depths shall not exceed 24 inches (610 mm) for clean sand or gravel and 8 inches (203 mm) for earth.

**R506.2.2 Base.** A 4-inch-thick (102 mm) base course consisting of clean graded sand, gravel, crushed stone, crushed concrete or crushed blast-furnace slag passing a 2-inch (51 mm) sieve shall be placed on the prepared subgrade **where the slab is below grade.**

**Exception:** A base course is not required where the concrete slab is installed on well-drained or sand-gravel mixture soils classified as Group I according to the United Soil Classification System in accordance with Table R405.1.

**R506.2.3 Vapor retarder.** A minimum 10-mil (0.010 inch; 0.254 mm) vapor retarder conforming to ASTM E1745 Class A requirements with joints lapped not less than 6 inches (152 mm) shall be placed between the concrete floor slab and the base course or the prepared subgrade where a base course does not exist.

**Exception:** The vapor retarder is not required for the following:

1. Garages, utility buildings and other unheated accessory structures.
2. For unheated storage rooms having an area of less than 70 square feet (6.5 m<sup>2</sup>) and carports.
3. Driveways, walks, patios and other flatwork not likely to be enclosed and heated at a later date.
4. Where *approved* by the building official, based on local site conditions.

**R506.2.4 Reinforcement support.** Where provided in slabs-on-ground, reinforcement shall be supported to remain in place from the center to upper one-third of the slab for the duration of the concrete placement.

## SECTION R507 EXTERIOR DECKS

**R507.1 Decks.** Wood-framed decks shall be in accordance with this section. Decks shall be designed for the *live load* required in Section R301.5 or the ground snow load indicated in Table R301.2, whichever is greater. For decks using materials and conditions not prescribed in this section, refer to Section R301.

**R507.2 Materials.** Materials used for the construction of decks shall comply with this section.

**R507.2.1 Wood materials.** Wood materials shall be No. 2 grade or better lumber, preservative-treated in accordance with Section R317, or *approved*, naturally durable lumber, and termite protected where required in accordance with Section R318. Where design in accordance with Section R301 is provided, wood structural members

shall be designed using the wet service factor defined in AWC NDS. Cuts, notches and drilled holes of preservative-treated wood members shall be treated in accordance with Section R317.1.1. All preservative-treated wood products in contact with the ground shall be *labeled* for such usage.

**R507.2.1.1 Engineered wood products.** Engineered wood products shall be in accordance with Section R502.

**R507.2.2 Plastic composite deck boards, stair treads, guards or handrails.** *Plastic composite* exterior deck boards, stair treads, *guards* and *handrails* shall comply with the requirements of ASTM D7032 and this section.

**R507.2.2.1 Labeling.** *Plastic composite* deck boards and stair treads, or their packaging, shall bear a *label* that indicates compliance with ASTM D7032 and includes the allowable load and maximum allowable span determined in accordance with ASTM D7032. *Plastic* or *composite handrails* and *guards*, or their packaging, shall bear a *label* that indicates compliance with ASTM D7032 and includes the maximum allowable span determined in accordance with ASTM D7032.

**R507.2.2.2 Flame spread index.** *Plastic composite* deck boards, stair treads, *guards*, and *handrails* shall exhibit a flame spread index not exceeding 200 when tested in accordance with ASTM E84 or UL 723 with the test specimen remaining in place during the test.

**Exception:** *Plastic composites* determined to be noncombustible.

**R507.2.2.3 Decay resistance.** *Plastic composite* deck boards, stair treads, *guards* and *handrails* containing wood, cellulosic or other biodegradable materials shall be decay resistant in accordance with ASTM D7032.

**R507.2.2.4 Termite resistance.** Where required by Section 318, *plastic composite* deck boards, stair treads, *guards* and *handrails* containing wood, cellulosic or other biodegradable materials shall be termite resistant in accordance with ASTM D7032.

**R507.2.2.5 Installation of plastic composites.** *Plastic composite* deck boards, stair treads, *guards* and *handrails* shall be installed in accordance with this code and the manufacturer's instructions.

**R507.2.3 Fasteners and connectors.** Metal fasteners and connectors used for all decks shall be in accordance with Section R317.3 and Table R507.2.3.

**R507.2.4 Flashing.** Flashing shall be corrosion-resistant metal of nominal thickness not less than 0.019 inch (0.48 mm) or *approved* nonmetallic material that is compatible with the substrate of the structure and the decking materials.

**R507.2.5 Alternate materials.** Alternative materials, including glass and metals, shall be permitted.

**TABLE R507.2.3**  
**FASTENER AND CONNECTOR SPECIFICATIONS FOR DECKS<sup>a, b</sup>**

ITEM	MATERIAL	MINIMUM FINISH/COATING	ALTERNATE FINISH/COATING <sup>c</sup>
Nails and glulam rivets	In accordance with ASTM F1667	Hot-dipped galvanized per ASTM A153, Class D for $\frac{3}{8}$ -inch diameter and less	Stainless steel, silicon bronze or copper
Bolts <sup>c</sup>	In accordance with ASTM A307 (bolts), ASTM A563 (nuts), ASTM F844 (washers)	Hot-dipped galvanized per ASTM A153, Class C (Class D for $\frac{3}{8}$ -inch diameter and less) or mechanically galvanized per ASTM B695, Class 55 or 410 stainless steel	Stainless steel, silicon bronze or copper
Lag screws <sup>d</sup> (including nuts and washers)			
Metal connectors	Per manufacturer's specification	ASTM A653 type G185 zinc-coated galvanized steel or post hot-dipped galvanized per ASTM A123 providing a minimum average coating weight of 2.0 oz./ft <sup>2</sup> (total both sides)	Stainless steel

For SI: 1 inch = 25.4 mm, 1 foot = 304.8 mm.

- a. Equivalent materials, coatings and finishes shall be permitted.
- b. Fasteners and connectors exposed to salt water or located within 300 feet of a salt water shoreline shall be stainless steel.
- c. Holes for bolts shall be drilled a minimum  $\frac{1}{32}$  inch and a maximum  $\frac{1}{16}$  inch larger than the bolt.
- d. Lag screws  $\frac{1}{2}$  inch and larger shall be predrilled to avoid wood splitting per the *National Design Specification (NDS) for Wood Construction*.
- e. Stainless-steel-driven fasteners shall be in accordance with ASTM F1667.

**R507.3 Footings.** Decks shall be supported on concrete footings or other *approved* structural systems designed to accommodate all loads in accordance with Section R301. Deck footings shall be sized to carry the imposed loads from the deck structure to the ground as shown in Figure R507.3.

**Exceptions:**

1. Footings shall not be required for free-standing decks consisting of joists directly supported on grade over their entire length.
2. Footings shall not be required for free-standing decks that meet all of the following criteria:
  - 2.1. The joists bear directly on *precast concrete* pier blocks at grade without support by beams or posts.

- 2.2. The area of the deck does not exceed 200 square feet (18.6 m<sup>2</sup>).
- 2.3. The walking surface is not more than 20 inches (508 mm) above grade at any point within 36 inches (914 mm) measured horizontally from the edge.

**R507.3.1 Minimum size.** The minimum size of concrete footings shall be in accordance with Table R507.3.1, based on the tributary area and allowable soil-bearing pressure in accordance with Table R401.4.1.

**R507.3.2 Minimum depth.** Deck footings shall be placed not less than 12 inches (305 mm) below the undisturbed ground surface.

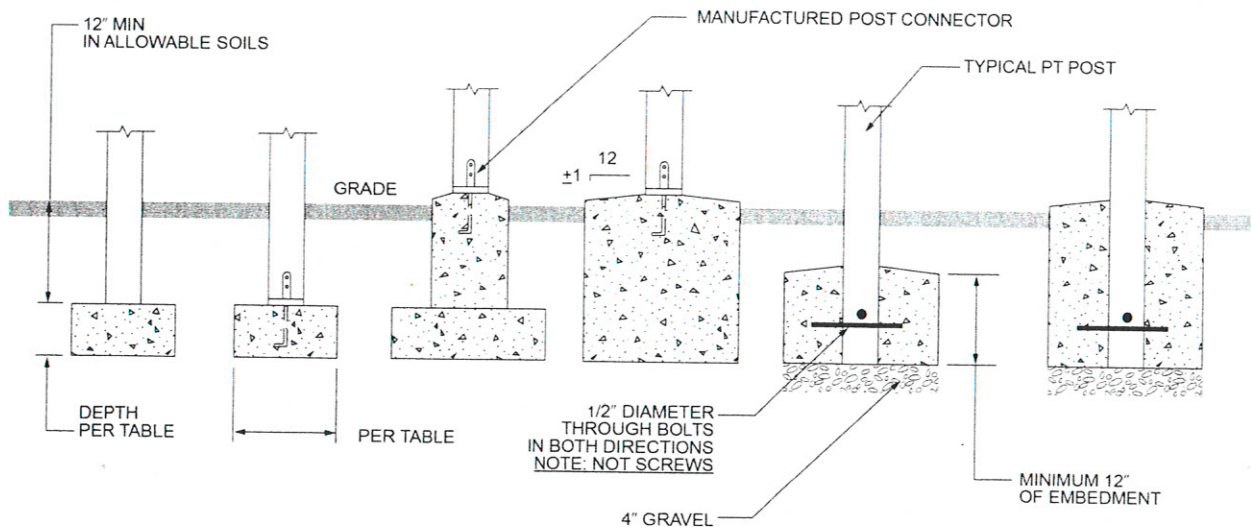

NOTE:  
POSTS MUST BE CENTERED ON OR IN FOOTING

For SI: 1 inch = 25.4 mm.

**FIGURE R507.3**  
**DECK POSTS TO DECK FOOTING CONNECTION**

TABLE R507.3.1  
MINIMUM FOOTING SIZE FOR DECKS

LIVE OR GROUND SNOW LOAD <sup>b</sup> (psf)	TRIBUTARY AREA (ft <sup>2</sup> )	LOAD-BEARING VALUE OF SOILS <sup>a, c, d</sup> (psf)								
		1,500 <sup>e</sup>			2,000 <sup>e</sup>			≥ 3,000 <sup>e</sup>		
		Side of a square footing (inches)	Diameter of a round footing (inches)	Thickness (inches) <sup>f</sup>	Side of a square footing (inches)	Diameter of a round footing (inches)	Thickness (inches) <sup>f</sup>	Side of a square footing (inches)	Diameter of a round footing (inches)	Thickness (inches) <sup>f</sup>
40	5	7	8	6	7	8	6	7	8	6
	20	10	12	6	9	9	6	7	8	6
	40	14	16	6	12	14	6	10	12	6
	60	17	19	6	15	17	6	12	14	6
	80	20	22	7	17	19	6	14	16	6
	100	22	25	8	19	21	6	15	17	6
	120	24	27	9	21	23	7	17	19	6
	140	26	29	10	22	25	8	18	21	6
160	28	31	11	24	27	9	20	22	7	
50	5	7	8	6	7	8	6	7	8	6
	20	11	13	6	10	11	6	8	9	6
	40	15	17	6	13	15	6	11	13	6
	60	19	21	6	16	18	6	13	15	6
	80	21	24	8	19	21	6	15	17	6
	100	24	27	9	21	23	7	17	19	6
	120	26	30	10	23	26	8	19	21	6
	140	28	32	11	25	28	9	20	23	7
160	30	34	12	26	30	10	21	24	8	
60	5	7	8	6	7	8	6	7	8	6
	20	12	14	6	11	12	6	9	10	6
	40	16	19	6	14	16	8	12	14	6
	60	20	23	7	17	20	6	14	16	6
	80	23	26	9	20	23	7	16	19	6
	100	26	29	10	22	25	8	18	21	6
	120	28	32	11	25	28	9	20	23	7
	140	31	35	12	27	30	10	22	24	8
160	33	37	13	28	32	11	23	26	9	
70	5	7	8	6	7	8	6	7	8	6
	20	12	14	6	11	13	6	9	10	6
	40	18	20	6	15	17	6	12	14	6
	60	21	24	8	19	21	6	15	17	6
	80	25	28	9	21	24	8	18	20	6
	100	28	31	11	24	27	9	20	22	7
	120	30	34	12	26	30	10	21	24	8
	140	33	37	13	28	32	11	23	26	9
160	35	40	15	30	34	12	25	28	9	

For SI: 1 inch = 25.4 mm, 1 square foot = 0.0929 m<sup>2</sup>, 1 pound per square foot = 0.0479 kPa.

- a. Interpolation permitted, extrapolation not permitted.
- b. Based on highest load case: Dead + Live or Dead + Snow.
- c. Footing dimensions shall allow complete bearing of the post.
- d. If the support is a brick or CMU pier, the footing shall have a minimum 2-inch projection on all sides.
- e. Area, in square feet, of deck surface supported by post and footings.
- f. Minimum thickness shall only apply to plain concrete footings.

**R507.3.3 Frost protection.** Where decks are attached to a frost-protected structure, deck footings shall be protected from frost by one or more of the following methods:

1. Extending below the frost line specified in Table R301.2.

2. Erecting on solid rock.
3. Other *approved* methods of frost protection.

**R507.4 Deck posts.** For single-level decks, wood post size shall be in accordance with Table R507.4.

**TABLE R507.4  
DECK POST HEIGHT**

LOADS (psf) <sup>b</sup>	POST SPECIES <sup>c</sup>	POST SIZE <sup>d</sup>	TRIBUTARY AREA (ft <sup>2</sup> ) <sup>g, h</sup>							
			20	40	60	80	100	120	140	160
			MAXIMUM DECK POST HEIGHT <sup>a</sup> (feet-inches)							
40 live load	Southern pine	4 × 4	14-0	13-8	11-0	9-5	8-4	7-5	6-9	6-2
		4 × 6	14-0	14-0	13-11	12-0	10-8	9-8	8-10	8-2
		6 × 6	14-0	14-0	14-0	14-0	14-0	14-0	14-0	14-0
		8 × 8	14-0	14-0	14-0	14-0	14-0	14-0	14-0	14-0
	Douglas fir <sup>e</sup> Hem-fir <sup>e</sup> Spruce-pine-fir <sup>e</sup>	4 × 4	14-0	13-6	10-10	9-3	8-0	7-0	6-2	5-3
		4 × 6	14-0	14-0	13-10	11-10	10-6	9-5	8-7	7-10
		6 × 6	14-0	14-0	14-0	14-0	14-0	14-0	14-0	14-0
		8 × 8	14-0	14-0	14-0	14-0	14-0	14-0	14-0	14-0
	Redwood <sup>f</sup> Western cedars <sup>f</sup> Ponderosa pine <sup>f</sup> Red pine <sup>f</sup>	4 × 4	14-0	13-2	10-3	8-1	5-8	NP	NP	NP
		4 × 6	14-0	14-0	13-6	11-4	9-9	8-4	6-9	4-7
		6 × 6	14-0	14-0	14-0	14-0	14-0	14-0	13-7	9-7
		8 × 8	14-0	14-0	14-0	14-0	14-0	14-0	14-0	14-0
50 ground snow load	Southern pine	4 × 4	14-0	12-2	9-10	8-5	7-5	6-7	5-11	5-4
		4 × 6	14-0	14-0	12-6	10-9	9-6	8-7	7-10	7-3
		6 × 6	14-0	14-0	14-0	14-0	14-0	14-0	14-0	13-4
		8 × 8	14-0	14-0	14-0	14-0	14-0	14-0	14-0	14-0
	Douglas fir <sup>e</sup> Hem-fir <sup>e</sup> Spruce-pine-fir <sup>e</sup>	4 × 4	14-0	12-1	9-8	8-2	7-1	6-2	5-3	4-2
		4 × 6	14-0	14-0	12-4	10-7	9-4	8-4	7-7	6-11
		6 × 6	14-0	14-0	14-0	14-0	14-0	14-0	14-0	12-10
		8 × 8	14-0	14-0	14-0	14-0	14-0	14-0	14-0	14-0
	Redwood <sup>f</sup> Western cedars <sup>f</sup> Ponderosa pine <sup>f</sup> Red pine <sup>f</sup>	4 × 4	14-0	11-8	9-0	6-10	3-7	NP	NP	NP
		4 × 6	14-0	14-0	12-0	10-0	8-6	7-0	5-3	NP
		6 × 6	14-0	14-0	14-0	14-0	14-0	14-0	10-8	2-4
		8 × 8	14-0	14-0	14-0	14-0	14-0	14-0	14-0	14-0
60 ground snow load	Southern pine	4 × 4	14-0	11-1	8-11	7-7	6-7	5-10	5-2	4-6
		4 × 6	14-0	14-0	11-4	9-9	8-7	7-9	7-1	6-6
		6 × 6	14-0	14-0	14-0	14-0	14-0	14-0	12-9	11-2
		8 × 8	14-0	14-0	14-0	14-0	14-0	14-0	14-0	14-0
	Douglas fir <sup>e</sup> Hem-fir <sup>e</sup> Spruce-pine-fir <sup>e</sup>	4 × 4	14-0	10-11	8-8	7-3	6-2	5-0	3-7	NP
		4 × 6	14-0	13-11	11-2	9-7	8-4	7-5	6-8	5-11
		6 × 6	14-0	14-0	14-0	14-0	14-0	14-0	12-2	10-2
		8 × 8	14-0	14-0	14-0	14-0	14-0	14-0	14-0	14-0
	Redwood <sup>f</sup> Western cedars <sup>f</sup> Ponderosa pine <sup>f</sup> Red pine <sup>f</sup>	4 × 4	14-0	10-6	7-9	4-7	NP	NP	NP	NP
		4 × 6	14-0	13-7	10-9	8-9	7-0	4-9	NP	NP
		6 × 6	14-0	14-0	14-0	14-0	14-0	9-9	NP	NP
		8 × 8	14-0	14-0	14-0	14-0	14-0	14-0	14-0	14-0

(continued)

TABLE R507.4—continued  
DECK POST HEIGHT

LOADS (psf) <sup>a</sup>	POST SPECIES <sup>c</sup>	POST SIZE <sup>d</sup>	TRIBUTARY AREA (ft <sup>2</sup> ) <sup>g, h</sup>							
			20	40	60	80	100	120	140	160
			MAXIMUM DECK POST HEIGHT <sup>a</sup> (feet-inches)							
70 ground snow load	Southern pine	4 × 4	14-0	10-2	8-2	6-11	5-11	5-2	4-4	3-4
		4 × 6	14-0	12-11	10-5	8-11	7-10	7-1	6-5	5-10
		6 × 6	14-0	14-0	14-0	14-0	14-0	12-9	10-11	8-7
		8 × 8	14-0	14-0	14-0	14-0	14-0	14-0	14-0	14-0
	Douglas fir <sup>e</sup> Hem-fir <sup>e</sup> Spruce-pine-fir <sup>e</sup>	4 × 4	14-0	10-1	7-11	6-6	5-3	3-7	NP	NP
		4 × 6	14-0	12-10	10-3	8-9	7-7	6-8	5-10	4-11
		6 × 6	14-0	14-0	14-0	14-0	14-0	12-2	9-9	5-9
		8 × 8	14-0	14-0	14-0	14-0	14-0	14-0	14-0	14-0
	Redwood <sup>f</sup> Western cedars <sup>f</sup> Ponderosa pine <sup>f</sup> Red pine <sup>f</sup>	4 × 4	14-0	9-5	6-5	NP	NP	NP	NP	NP
		4 × 6	14-0	12-6	9-8	7-7	5-3	NP	NP	NP
		6 × 6	14-0	14-0	14-0	14-0	10-8	NP	NP	NP
		8 × 8	14-0	14-0	14-0	14-0	14-0	14-0	14-0	14-0

For SI: 1 inch = 25.4 mm, 1 foot = 304.8 mm, 1 pound per square foot = 0.0479 kPa.

NP = Not Permitted.

- Measured from the underside of the beam to the top of footing or pier.
- 10 psf dead load. Snow load not assumed to be concurrent with live load.
- No. 2 grade, wet service factor included.
- Notched deck posts shall be sized to accommodate beam size in accordance with Section R507.5.2.
- Includes incising factor.
- Incising factor not included.
- Area, in square feet, of deck surface supported by post and footings.
- Interpolation permitted. Extrapolation not permitted.

**R507.4.1 Deck post to deck footing connection.** Where posts bear on concrete footings in accordance with Section R403 and Figure R507.3, lateral restraint shall be provided by manufactured connectors or a minimum post embedment of 12 inches (305 mm) in surrounding soils or concrete piers. Other footing systems shall be permitted.

**Exception:** Where expansive, compressible, shifting or other questionable soils are present, surrounding soils shall not be relied on for lateral support.

**R507.5 Deck beams.** Maximum allowable spans for wood deck beams, as shown in Figure R507.5, shall be in accordance with Tables R507.5(1) through R507.5(4). Beam plies shall be fastened together with two rows of 10d (3-inch × 0.128-inch) nails minimum at 16 inches (406 mm) on center along each edge. Beams shall be permitted to cantilever at each end up to one-fourth of the actual beam span. Deck beams of other materials shall be permitted where designed in accordance with accepted engineering practices.

**R507.5.1 Deck beam bearing.** The ends of beams shall have not less than 1½ inches (38 mm) of bearing on wood or metal and not less than 3 inches (76 mm) of bearing on concrete or masonry for the entire width of the beam. Where multiple-span beams bear on intermediate posts, each ply must have full bearing on the post in accordance with Figures R507.5.1(1) and R507.5.1(2).

**R507.5.2 Deck beam connection to supports.** Deck beams shall be attached to supports in a manner capable of transferring vertical loads and resisting horizontal displacement. Deck beam connections to wood posts shall be in accordance with Figures R507.5.1(1) and R507.5.1(2). Manufactured post-to-beam connectors shall be sized for the post and beam sizes. Bolts shall have washers under the head and nut.

**R507.6 Deck joists.** Maximum allowable spans for wood deck joists, as shown in Figure R507.6, shall be in accordance with Table R507.6. The maximum joist spacing shall be limited by the decking materials in accordance with Table R507.7.

**R507.6.1 Deck joist bearing.** The ends of joists shall have not less than 1½ inches (38 mm) of bearing on wood or metal and not less than 3 inches (76 mm) of bearing on concrete or masonry over its entire width. Joists bearing on top of a multiple-ply beam or ledger shall be fastened in accordance with Table R602.3(1). Joists bearing on top of a single-ply beam or ledger shall be attached by a mechanical connector. Joist framing into the side of a beam or ledger board shall be supported by *approved* joist hangers.

**R507.6.2 Deck joist lateral restraint.** Joist ends and bearing locations shall be provided with lateral resistance to prevent rotation. Where lateral restraint is provided by joist hangers or blocking between joists, their depth shall

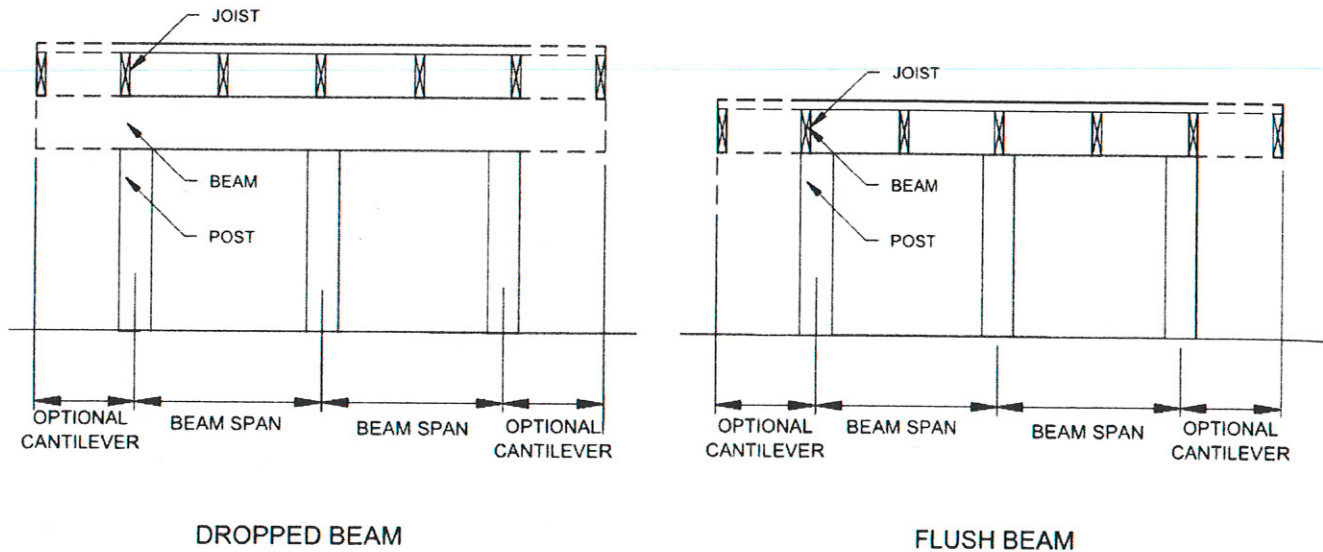

FIGURE R507.5  
TYPICAL DECK JOIST SPANS

equal not less than 60 percent of the joist depth. Where lateral restraint is provided by rim joists, they shall be secured to the end of each joist with not fewer than three 10d (3-inch by 0.128-inch) (76 mm by 3.3 mm) nails or three No. 10 x 3-inch-long (76 mm) wood screws.

**R507.7 Decking.** Maximum allowable spacing for joists supporting wood decking, excluding *stairways*, shall be in accordance with Table R507.7. Wood decking shall be attached to each supporting member with not less than two 8d threaded nails or two No. 8 wood screws. Maximum allowable spacing for joists supporting *plastic composite* decking shall be in accordance with Section R507.2. Other *approved* decking or fastener systems shall be installed in accordance with the manufacturer's installation requirements.

**R507.8 Vertical and lateral supports.** Where supported by attachment to an exterior wall, decks shall be positively anchored to the primary structure and designed for both vertical and lateral loads. Such attachment shall not be accomplished by the use of toenails or nails subject to withdrawal. For decks with cantilevered framing members, connection to exterior walls or other framing members shall be designed and constructed to resist uplift resulting from the full *live load* specified in Table R301.5 acting on the cantilevered portion of the deck. Where positive connection to the

primary building structure cannot be verified during inspection, decks shall be self-supporting.

**R507.9 Vertical and lateral supports at band joist.** Vertical and lateral supports for decks shall comply with this section.

**R507.9.1 Vertical supports.** Vertical loads shall be transferred to band joists with ledgers in accordance with this section.

**R507.9.1.1 Ledger details.** Deck ledgers shall be a minimum 2-inch by 8-inch (51 mm by 203 mm) nominal, pressure-preservative-treated Southern pine, incised pressure-preservative-treated hem-fir, or *approved*, naturally durable, No. 2 grade or better lumber. Deck ledgers shall not support concentrated loads from beams or girders. Deck ledgers shall not be supported on stone or masonry veneer.

**R507.9.1.2 Band joist details.** Band joists supporting a ledger shall be a minimum 2-inch-nominal (51 mm), solid-sawn, spruce-pine-fir or better lumber or a minimum 1-inch (25 mm) nominal engineered wood rim boards in accordance with Section R502.1.7. Band joists shall bear fully on the primary structure capable of supporting all required loads.

S  
D  
H  
S  
R  
V  
P  
R  
For  
a.)  
b.)  
c.)  
d.)  
e.)  
f.)  
g.)  
h.)  
i.)  
j.)

**TABLE R507.5(1)**  
**MAXIMUM DECK BEAM SPAN—40 PSF LIVE LOAD<sup>c</sup>**

BEAM SPECIES <sup>d</sup>	BEAM SIZE <sup>e</sup>	EFFECTIVE DECK JOIST SPAN LENGTH <sup>a,i,j</sup> (feet)						
		6	8	10	12	14	16	18
		MAXIMUM DECK BEAM SPAN LENGTH (feet-inches) <sup>a,b,f</sup>						
Southern pine	1-2 x 6	4-7	4-0	3-7	3-3	3-0	2-10	2-8
	1-2 x 8	5-11	5-1	4-7	4-2	3-10	3-7	3-5
	1-2 x 10	7-0	6-0	5-5	4-11	4-7	4-3	4-0
	1-2 x 12	8-3	7-1	6-4	5-10	5-5	5-0	4-9
	2-2 x 6	6-11	5-11	5-4	4-10	4-6	4-3	4-0
	2-2 x 8	8-9	7-7	6-9	6-2	5-9	5-4	5-0
	2-2 x 10	10-4	9-0	8-0	7-4	6-9	6-4	6-0
	2-2 x 12	12-2	10-7	9-5	8-7	8-0	7-5	7-0
	3-2 x 6	8-6	7-5	6-8	6-1	5-8	5-3	4-11
	3-2 x 8	10-11	9-6	8-6	7-9	7-2	6-8	6-4
	3-2 x 10	13-0	11-2	10-0	9-2	8-6	7-11	7-6
	3-2 x 12	15-3	13-3	11-10	10-9	10-0	9-4	8-10
Douglas fir-larch <sup>g</sup> Hem-fir <sup>g</sup> Spruce-pine-fir	1-2 x 6	4-1	3-6	3-0	2-8	2-5	2-3	2-1
	1-2 x 8	5-6	4-8	4-0	3-6	3-2	2-11	2-9
	1-2 x 10	6-8	5-10	5-1	4-6	4-1	3-9	3-6
	1-2 x 12	7-9	6-9	6-0	5-6	5-0	3-9	3-6
	2-2 x 6	6-1	5-3	4-9	4-4	3-11	3-7	3-3
	2-2 x 8	8-2	7-1	6-4	5-9	5-2	4-8	4-4
	2-2 x 10	10-0	8-7	7-9	7-0	6-6	6-0	5-6
	2-2 x 12	11-7	10-0	8-11	8-2	7-7	7-1	6-8
	3-2 x 6	7-8	6-8	6-0	5-6	5-1	4-9	4-6
	3-2 x 8	10-3	8-10	7-11	7-3	6-8	6-3	5-11
	3-2 x 10	12-6	10-10	9-8	8-10	8-2	7-8	7-2
	3-2 x 12	14-6	12-7	11-3	10-3	9-6	8-11	8-5
Redwood <sup>h</sup> Western cedars <sup>h</sup> Ponderosa pine <sup>h</sup> Red pine <sup>h</sup>	1-2 x 6	4-2	3-7	3-1	2-9	2-6	2-3	2-2
	1-2 x 8	5-4	4-7	4-1	3-7	3-3	3-0	2-10
	1-2 x 10	6-6	5-7	5-0	4-7	4-2	3-10	3-7
	1-2 x 12	7-6	6-6	5-10	5-4	4-11	4-7	4-4
	2-2 x 6	6-2	5-4	4-10	4-5	4-0	3-8	3-4
	2-2 x 8	7-10	6-10	6-1	5-7	5-2	4-10	4-5
	2-2 x 10	9-7	8-4	7-5	6-9	6-3	5-10	5-6
	2-2 x 12	11-1	9-8	8-7	7-10	7-3	6-10	6-5
	3-2 x 6	7-8	6-9	6-0	5-6	5-1	4-9	4-6
	3-2 x 8	9-10	8-6	7-7	6-11	6-5	6-0	5-8
	3-2 x 10	12-0	10-5	9-4	8-6	7-10	7-4	6-11
	3-2 x 12	13-11	12-1	10-9	9-10	9-1	8-6	8-1

For SI: 1 inch = 25.4 mm, 1 foot = 304.8 mm, 1 pound per square foot = 0.0479 kPa, 1 pound = 0.454 kg.

- a. Interpolation permitted. Extrapolation not permitted.
- b. Beams supporting a single span of joists with or without cantilever.
- c. Dead load = 10 psf.  $L/\Delta = 360$  at main span,  $L/\Delta = 180$  at cantilever. Snow load is not assumed to be concurrent with live load.
- d. No. 2 grade, wet service factor included.
- e. Beam depth shall be equal to or greater than the depth of intersecting joist for a flush beam connection.
- f. Beam cantilevers are limited to the adjacent beam's span divided by 4.
- g. Includes incising factor.
- h. Incising factor not included.
- i. Deck joist span as shown in Figure R507.5.
- j. For calculation of effective deck joist span, the actual joist span length shall be multiplied by the joist span factor in accordance with Table R507.5(5).

TABLE R507.5(2)  
MAXIMUM DECK BEAM SPAN—50 PSF GROUND SNOW LOAD<sup>c</sup>

BEAM SPECIES <sup>d</sup>	BEAM SIZE <sup>e</sup>	EFFECTIVE DECK JOIST SPAN LENGTH (feet) <sup>a, i, j</sup>						
		6	8	10	12	14	16	18
		MAXIMUM DECK BEAM SPAN LENGTH (feet-inches) <sup>a, b, f</sup>						
Southern pine	1-2 x 6	4-6	3-11	3-6	3-2	2-11	2-9	2-7
	1-2 x 8	5-9	4-11	4-5	4-0	3-9	3-6	3-3
	1-2 x 10	6-9	5-10	5-3	4-9	4-5	4-2	3-11
	1-2 x 12	8-0	6-11	6-2	5-8	5-3	4-11	4-7
	2-2 x 6	6-8	5-9	5-2	4-9	4-4	4-1	3-10
	2-2 x 8	8-6	7-4	6-7	6-0	5-7	5-2	4-11
	2-2 x 10	10-1	8-9	7-10	7-1	6-7	6-2	5-10
	2-2 x 12	11-11	10-3	9-2	8-5	7-9	7-3	6-10
	3-2 x 6	7-11	7-2	6-6	5-11	5-6	5-1	4-10
	3-2 x 8	10-5	9-3	8-3	7-6	6-11	6-6	6-2
	3-2 x 10	12-8	10-11	9-9	8-11	8-3	7-9	7-3
	3-2 x 12	14-11	12-11	11-6	10-6	9-9	9-1	8-7
Douglas fir-larch <sup>g</sup> Hem-fir <sup>g</sup> Spruce-pine-fir <sup>g</sup>	1-2 x 6	4-0	3-5	2-11	2-7	2-4	2-2	2-0
	1-2 x 8	5-4	4-7	3-11	3-5	3-1	2-10	2-8
	1-2 x 10	6-7	5-8	4-11	4-5	4-0	3-8	3-5
	1-2 x 12	7-7	6-7	5-11	5-4	4-10	4-6	4-2
	2-2 x 6	6-0	5-2	4-7	4-2	3-10	3-5	3-2
	2-2 x 8	8-0	6-11	6-2	5-8	5-0	4-7	4-2
	2-2 x 10	9-9	8-5	7-7	6-11	6-4	5-10	5-4
	2-2 x 12	11-4	9-10	8-9	8-0	7-5	6-11	6-6
	3-2 x 6	7-6	6-6	5-9	5-3	4-11	4-7	4-4
	3-2 x 8	10-0	8-8	7-9	7-1	6-6	6-1	5-8
	3-2 x 10	12-3	10-7	9-6	8-8	8-0	7-6	7-0
3-2 x 12	14-3	12-4	11-0	10-1	9-4	8-9	8-3	
Redwood <sup>h</sup> Western cedars <sup>h</sup> Ponderosa pine <sup>h</sup> Red pine <sup>h</sup>	1-2 x 6	4-1	3-6	3-0	2-8	2-5	2-3	2-1
	1-2 x 8	5-2	4-6	4-0	3-6	3-2	2-11	2-9
	1-2 x 10	6-4	5-6	4-11	4-6	4-1	3-9	3-6
	1-2 x 12	7-4	6-4	5-8	5-2	4-10	4-6	4-3
	2-2 x 6	6-1	5-3	4-8	4-4	3-11	3-6	3-3
	2-2 x 8	7-8	6-8	5-11	5-5	5-0	4-8	4-3
	2-2 x 10	9-5	8-2	7-3	6-8	6-2	5-9	5-5
	2-2 x 12	10-11	9-5	8-5	7-8	7-2	6-8	6-3
	3-2 x 6	7-1	6-5	5-11	5-5	5-0	4-8	4-5
	3-2 x 8	9-4	8-4	7-5	6-10	6-0	5-11	5-7
	3-2 x 10	11-9	10-2	9-1	8-4	7-8	7-2	6-9
	3-2 x 12	13-8	11-10	10-7	9-8	8-11	8-4	7-10

For SI: 25.4 mm, 1 foot = 304.8 mm, 1 pound per square foot = 0.0479 kPa, 1 pound = 0.454 kg.

- a. Interpolation allowed. Extrapolation is not allowed.
- b. Beams supporting a single span of joists with or without cantilever.
- c. Dead load = 10 psf,  $L/\Delta = 360$  at main span,  $L/\Delta = 180$  at cantilever. Snow load not assumed to be concurrent with live load.
- d. No. 2 grade, wet service factor included.
- e. Beam depth shall be equal to or greater than the depth of intersecting joist for a flush beam connection.
- f. Beam cantilevers are limited to the adjacent beam's span divided by 4.
- g. Includes incising factor.
- h. Incising factor not included.
- i. Deck joist span as shown in Figure R507.5.
- j. For calculation of effective deck joist span, the actual joist span length shall be multiplied by the joist span factor in accordance with Table R507.5(5).

**TABLE R507.5(3)**  
**MAXIMUM DECK BEAM SPAN—60 PSF GROUND SNOW LOAD<sup>c</sup>**

BEAM SPECIES <sup>d</sup>	BEAM SIZE <sup>e</sup>	EFFECTIVE DECK JOIST SPAN LENGTH <sup>a,i,j</sup> (feet)						
		6	8	10	12	14	16	18
		MAXIMUM DECK BEAM SPAN LENGTH (feet-inches) <sup>a,b,f</sup>						
Southern pine	1-2 x 6	4-2	3-7	3-3	2-11	2-9	2-6	2-5
	1-2 x 8	5-3	4-7	4-1	3-9	3-5	3-3	3-0
	1-2 x 10	6-3	5-5	4-10	4-5	4-1	3-10	3-7
	1-2 x 12	7-5	6-5	5-9	5-3	4-10	4-6	4-3
	2-2 x 6	6-2	5-4	4-9	4-4	4-0	3-9	3-7
	2-2 x 8	7-10	6-10	6-1	5-7	5-2	4-10	4-6
	2-2 x 10	9-4	8-1	7-3	6-7	6-1	5-8	5-4
	2-2 x 12	11-0	9-6	8-6	7-9	7-2	6-9	6-4
	3-2 x 6	7-5	6-9	6-0	5-6	5-1	4-9	4-6
	3-2 x 8	9-9	8-6	7-8	6-11	6-5	6-0	5-8
	3-2 x 10	11-8	10-2	9-1	8-3	7-8	7-2	6-9
	3-2 x 12	13-9	11-11	10-8	9-9	9-0	8-5	7-11
Douglas fir-larch <sup>g</sup> Hem-fir <sup>g</sup> Spruce-pine-fir <sup>g</sup>	1-2 x 6	3-8	3-1	2-8	2-4	2-2	2-0	1-10
	1-2 x 8	5-0	4-1	3-6	3-1	2-10	2-7	2-5
	1-2 x 10	6-1	5-2	4-6	4-0	3-7	3-4	3-2
	1-2 x 12	7-1	6-1	5-5	4-10	4-5	4-1	3-10
	2-2 x 6	5-6	4-9	4-3	3-10	3-5	3-1	2-10
	2-2 x 8	7-5	6-5	5-9	5-0	4-6	4-1	3-9
	2-2 x 10	9-0	7-10	7-0	6-4	5-9	5-2	4-10
	2-2 x 12	10-6	9-1	8-1	7-5	6-10	6-4	5-10
	3-2 x 6	6-11	6-0	5-4	4-11	4-6	4-2	3-10
	3-2 x 8	9-3	8-0	7-2	6-6	6-1	5-6	5-0
	3-2 x 10	11-4	9-10	8-9	8-0	7-5	6-11	6-5
	3-2 x 12	13-2	11-5	10-2	9-4	8-7	8-1	7-7
Redwood <sup>h</sup> Western cedars <sup>h</sup> Ponderosa pine <sup>h</sup> Red pine <sup>h</sup>	1-2 x 6	3-9	3-2	2-9	2-5	2-2	2-0	1-11
	1-2 x 8	4-10	4-2	3-7	3-2	2-11	2-8	2-6
	1-2 x 10	5-10	5-1	4-6	4-1	3-8	3-5	3-3
	1-2 x 12	6-10	5-11	5-3	4-10	4-5	4-2	3-11
	2-2 x 6	5-7	4-10	4-4	3-11	3-6	3-2	2-11
	2-2 x 8	7-1	6-2	5-6	5-0	4-7	4-2	3-10
	2-2 x 10	8-8	7-6	6-9	6-2	5-8	5-4	4-11
	2-2 x 12	10-1	8-9	7-10	7-2	6-7	6-2	5-10
	3-2 x 6	6-8	6-1	5-5	5-0	4-7	4-3	3-11
	3-2 x 8	8-9	7-9	6-22	6-4	5-20	5-5	5-3
	3-2 x 10	10-11	9-5	8-5	7-8	7-3	6-8	6-3
	3-2 x 12	12-8	10-11	9-9	8-11	8-3	7-9	7-3

For SI: 1 inch = 25.4 mm, 1 foot = 304.8 mm, 1 pound per square foot = 0.0479 kPa, 1 pound = 0.454 kg.

a. Interpolation allowed. Extrapolation is not allowed.

b. Beams supporting a single span of joists with or without cantilever.

c. Dead load = 10 psf,  $L/\Delta = 360$  at main span,  $L/\Delta = 180$  at cantilever. Snow load not assumed to be concurrent with live load.

d. No. 2 grade, wet service factor included.

e. Beam depth shall be equal to or greater than the depth of intersecting joist for a flush beam connection.

f. Beam cantilevers are limited to the adjacent beam's span divided by 4.

g. Includes incising factor.

h. Incising factor not included.

i. Deck joist span as shown in Figure R507.5.

j. For calculation of effective deck joist span, the actual joist span length shall be multiplied by the joist span factor in accordance with Table R507.5(5).

TABLE R507.5(4)  
MAXIMUM DECK BEAM SPAN—70 PSF GROUND SNOW LOAD<sup>c</sup>

BEAM SPECIES <sup>d</sup>	BEAM SIZE <sup>e</sup>	EFFECTIVE DECK JOIST SPAN LENGTH (feet) <sup>a, i, j</sup>						
		6	8	10	12	14	16	18
		MAXIMUM DECK BEAM SPAN LENGTH (feet-inches) <sup>a, b, f</sup>						
Southern pine	1-2 x 6	3-11	3-4	3-0	2-9	2-6	2-4	2-3
	1-2 x 8	4-11	4-3	3-10	3-6	3-3	3-0	2-10
	1-2 x 10	5-10	5-1	4-6	4-2	3-10	3-7	3-4
	1-2 x 12	6-11	6-0	5-4	4-11	4-6	4-3	4-0
	2-2 x 6	5-9	5-0	4-6	4-1	3-9	3-6	3-4
	2-2 x 8	7-4	6-4	5-8	5-2	4-10	4-6	4-3
	2-2 x 10	8-9	7-7	6-9	6-2	5-8	5-4	5-0
	2-2 x 12	10-3	8-11	8-0	7-3	6-9	6-3	5-11
	3-2 x 6	7-0	6-3	5-7	5-1	4-9	4-5	4-2
	3-2 x 8	9-3	8-0	7-2	6-6	6-0	5-8	5-4
	3-2 x 10	10-11	9-6	8-6	7-9	7-2	6-8	6-4
	3-2 x 12	12-11	11-2	10-0	9-1	8-5	7-11	7-5
Douglas fir-larch <sup>g</sup> Hem-fir <sup>g</sup> Spruce-pine-fir <sup>g</sup>	1-2 x 6	3-5	2-10	2-5	2-2	2-0	1-10	1-9
	1-2 x 8	4-7	3-8	3-2	2-10	2-7	2-5	2-4
	1-2 x 10	5-8	4-9	4-1	3-8	3-4	3-1	2-11
	1-2 x 12	6-7	5-8	5-0	4-6	4-1	3-10	3-7
	2-2 x 6	5-2	4-6	4-0	3-5	3-1	2-10	2-7
	2-2 x 8	6-11	6-0	5-3	4-7	4-1	3-8	3-5
	2-2 x 10	8-5	7-4	6-6	5-10	5-2	4-9	4-5
	2-2 x 12	9-10	8-6	7-7	6-11	6-4	5-9	5-4
	3-2 x 6	6-6	5-7	5-0	4-7	4-2	3-9	3-5
	3-2 x 8	8-8	7-6	6-8	6-1	5-6	5-0	4-7
	3-2 x 10	10-7	9-2	8-2	7-6	6-11	6-4	5-10
	3-2 x 12	12-4	10-8	9-7	8-9	8-1	7-7	7-1
Redwood <sup>h</sup> Western cedars <sup>h</sup> Ponderosa pine <sup>h</sup> Red pine <sup>h</sup>	1-2 x 6	3-6	2-11	2-6	2-3	2-0	1-11	1-9
	1-2 x 8	4-6	3-10	3-3	2-11	2-8	2-6	2-4
	1-2 x 10	5-6	4-9	4-2	3-9	3-5	3-2	3-0
	1-2 x 12	6-4	5-6	4-11	4-6	4-2	3-11	3-8
	2-2 x 6	5-3	4-7	4-1	3-6	3-2	2-11	2-8
	2-2 x 8	6-8	5-9	5-2	4-8	4-2	3-10	3-6
	2-2 x 10	8-2	7-1	6-4	5-9	5-4	4-10	4-6
	2-2 x 12	9-5	8-2	7-4	6-8	6-2	5-9	5-5
	3-2 x 6	6-4	5-8	5-1	4-8	4-3	3-10	3-6
	3-2 x 8	8-4	7-3	6-5	5-11	5-5	5-1	4-8
	3-2 x 10	10-2	8-10	7-11	7-2	6-8	6-3	5-11
	3-2 x 12	11-10	10-3	9-2	8-4	7-9	7-3	6-10

For SI: 1 inch = 25.4 mm, 1 foot = 304.8 mm, 1 pound per square foot = 0.0479 kPa, 1 pound = 0.454 kg.

- a. Interpolation allowed. Extrapolation is not allowed.
- b. Beams supporting a single span of joists with or without cantilever.
- c. Dead load = 10 psf,  $L/\Delta = 360$  at main span,  $L/\Delta = 180$  at cantilever. Snow load not assumed to be concurrent with live load.
- d. No. 2 grade, wet service factor included.
- e. Beam depth shall be equal to or greater than the depth of intersecting joist for a flush beam connection.
- f. Beam cantilevers are limited to the adjacent beam's span divided by 4.
- g. Includes incising factor.
- h. Incising factor not included.
- i. Deck joist span as shown in Figure R507.5.
- j. For calculation of effective deck joist span, the actual joist span length shall be multiplied by the joist span factor in accordance with Table R507.5(5).

For SI:  
a. C = a

For SI

**TABLE R507.5(5)**  
**JOIST SPAN FACTORS FOR CALCULATING EFFECTIVE DECK JOIST SPAN**  
 [for use with Note j in Tables R507.5(1), R507.5(2), R507.5(3) and R507.5(4)]

C/J <sup>a</sup>	JOIST SPAN FACTOR
0 (no cantilever)	0.66
1/12 (0.87)	0.72
1/10 (0.10)	0.80
1/8 (0.125)	0.84
1/6 (0.167)	0.90
1/4 (0.250)	1.00

For SI: 1 foot = 304.8 mm.

a. C = actual joist cantilever length (feet); J = actual joist span length (feet).

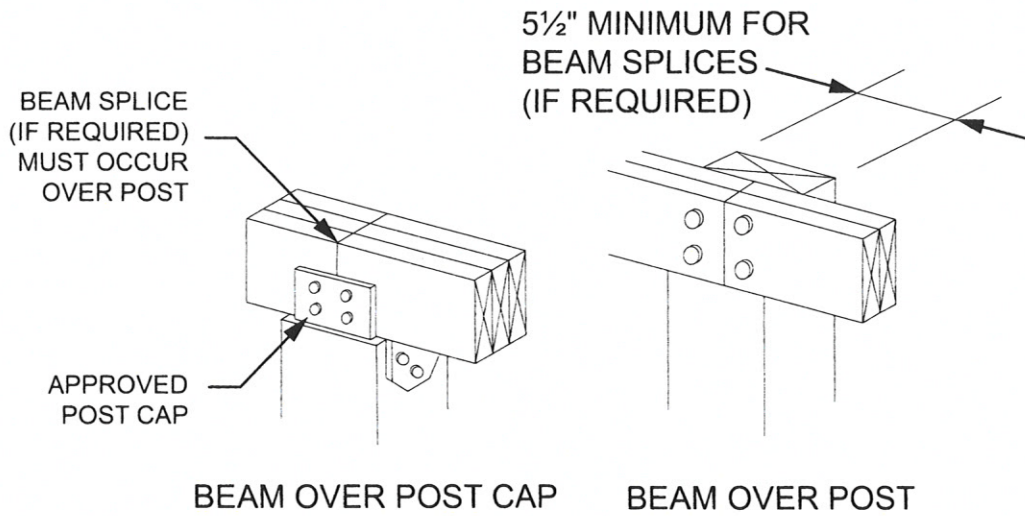

For SI: 1 inch = 25.4 mm.

**FIGURE R507.5.1(1)**  
**DECK BEAM TO DECK POST**

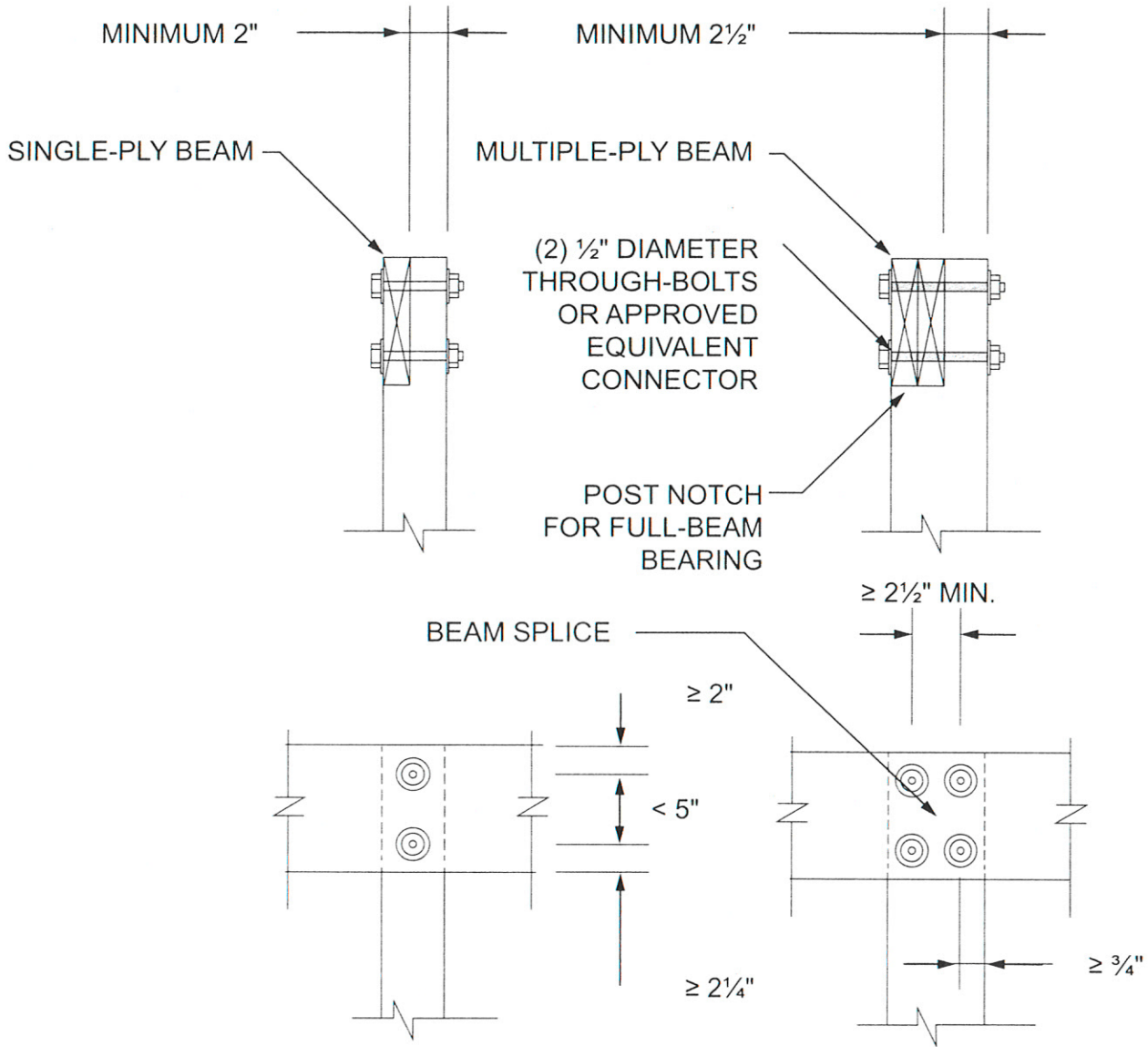

For SI: 1 inch = 25.4 mm.

FIGURE R507.5.1(2)  
NOTCHED POST-TO-BEAM CONNECTION

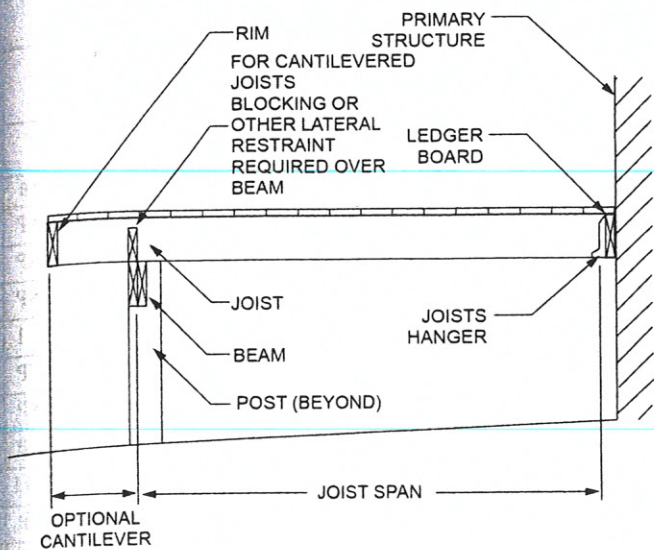

CANTILEVERED JOISTS WITH DROPPED BEAM

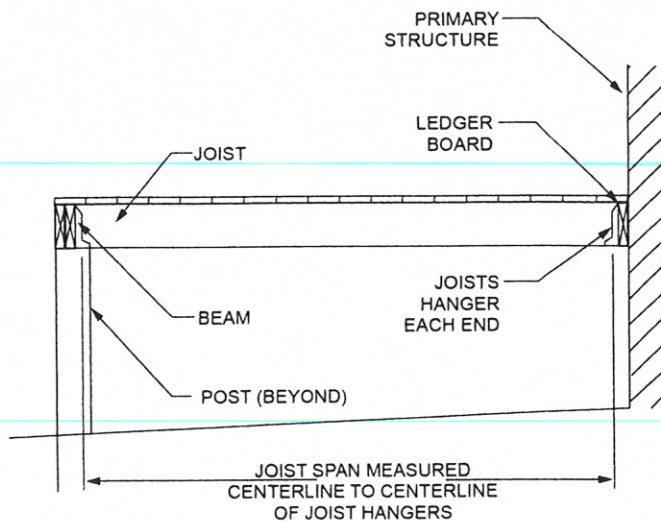

JOISTS WITH FLUSH BEAM

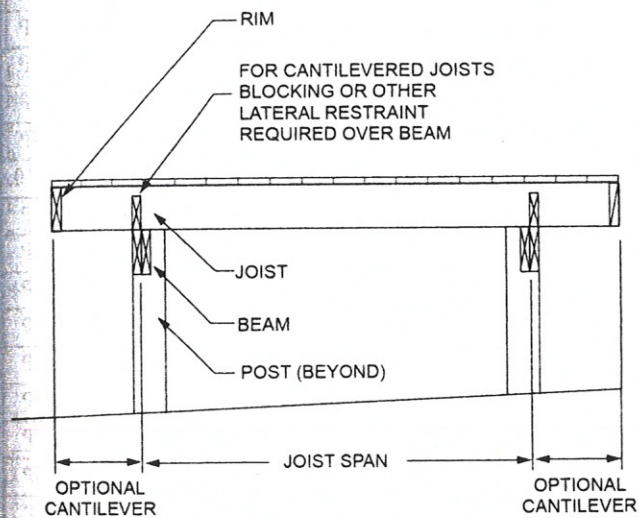

JOISTS ON FREE-STANDING DECK WITH DROPPED BEAM

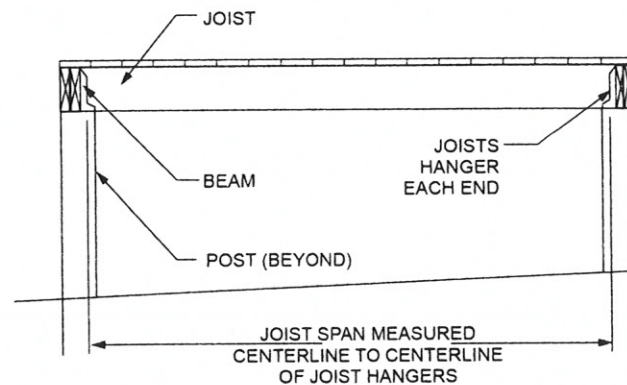

JOISTS ON FREE-STANDING DECK WITH FLUSH BEAM

FIGURE R507.6  
TYPICAL DECK JOIST SPANS

TABLE R507.6  
MAXIMUM DECK JOIST SPANS

LOAD <sup>a</sup> (psf)	JOIST SPECIES <sup>b</sup>	JOIST SIZE	ALLOWABLE JOIST SPAN <sup>b, c</sup> (feet-inches)			MAXIMUM CANTILEVER <sup>d, f</sup> (feet-inches)							
			Joist spacing (inches)			Joist back span <sup>g</sup> (feet)							
			12	16	24	4	6	8	10	12	14	16	18
40 live load	Southern pine	2 x 6	9-11	9-0	7-7	1-0	1-6	1-5	NP	NP	NP	NP	NP
		2 x 8	13-1	11-10	9-8	1-0	1-6	2-0	2-6	2-3	NP	NP	NP
		2 x 10	16-2	14-0	11-5	1-0	1-6	2-0	2-6	3-0	3-4	3-4	NP
		2 x 12	18-0	16-6	13-6	1-0	1-6	2-0	2-6	3-0	3-6	4-0	4-1
	Douglas fir-larch <sup>e</sup> Hem-fir <sup>e</sup> Spruce-pine-fir <sup>e</sup>	2 x 6	9-6	8-4	6-10	1-0	1-6	1-4	NP	NP	NP	NP	NP
		2 x 8	12-6	11-1	9-1	1-0	1-6	2-0	2-3	2-0	NP	NP	NP
		2 x 10	15-8	13-7	11-1	1-0	1-6	2-0	2-6	3-0	3-3	NP	NP
		2 x 12	18-0	15-9	12-10	1-0	1-6	2-0	2-6	3-0	3-6	3-11	3-11
	Redwood <sup>f</sup> Western cedars <sup>f</sup> Ponderosa pine <sup>f</sup> Red pine <sup>f</sup>	2 x 6	8-10	8-0	6-10	1-0	1-4	1-1	NP	NP	NP	NP	NP
		2 x 8	11-8	10-7	8-8	1-0	1-6	2-0	1-11	NP	NP	NP	NP
		2 x 10	14-11	13-0	10-7	1-0	1-6	2-0	2-6	3-0	2-9	NP	NP
		2 x 12	17-5	15-1	12-4	1-0	1-6	2-0	2-6	3-0	3-6	3-8	NP
50 ground snow load	Southern pine	2 x 6	9-2	8-4	7-4	1-0	1-6	1-5	NP	NP	NP	NP	NP
		2 x 8	12-1	11-0	9-5	1-0	1-6	2-0	2-5	2-3	NP	NP	NP
		2 x 10	15-5	13-9	11-3	1-0	1-6	2-0	2-6	3-0	3-1	NP	NP
		2 x 12	18-0	16-2	13-2	1-0	1-6	2-0	2-6	3-0	3-6	3-10	3-10
	Douglas fir-larch <sup>e</sup> Hem-fir <sup>e</sup> Spruce-pine-fir <sup>e</sup>	2 x 6	8-10	8-0	6-8	1-0	1-6	1-4	NP	NP	NP	NP	NP
		2 x 8	11-7	10-7	8-11	1-0	1-6	2-0	2-3	NP	NP	NP	NP
		2 x 10	14-10	13-3	10-10	1-0	1-6	2-0	2-6	3-0	3-0	NP	NP
		2 x 12	17-9	15-5	12-7	1-0	1-6	2-0	2-6	3-0	3-6	3-8	NP
	Redwood <sup>f</sup> Western cedars <sup>f</sup> Ponderosa pine <sup>f</sup> Red pine <sup>f</sup>	2 x 6	8-3	7-6	6-6	1-0	1-4	1-1	NP	NP	NP	NP	NP
		2 x 8	10-10	9-10	8-6	1-0	1-6	2-0	1-11	NP	NP	NP	NP
		2 x 10	13-10	12-7	10-5	1-0	1-6	2-0	2-6	2-9	NP	NP	NP
		2 x 12	16-10	14-9	12-1	1-0	1-6	2-0	2-6	3-0	3-5	3-5	NP
60 ground snow load	Southern pine	2 x 6	8-8	7-10	6-10	1-0	1-6	1-5	NP	NP	NP	NP	NP
		2 x 8	11-5	10-4	8-9	1-0	1-6	2-0	2-4	NP	NP	NP	NP
		2 x 10	14-7	12-9	10-5	1-0	1-6	2-0	2-6	2-11	2-11	NP	NP
		2 x 12	17-3	15-0	12-3	1-0	1-6	2-0	2-6	3-0	3-6	3-7	NP
	Douglas fir-larch <sup>e</sup> Hem-fir <sup>e</sup> Spruce-pine-fir <sup>e</sup>	2 x 6	8-4	7-6	6-2	1-0	1-6	1-4	NP	NP	NP	NP	NP
		2 x 8	10-11	9-11	8-3	1-0	1-6	2-0	2-2	NP	NP	NP	NP
		2 x 10	13-11	12-4	10-0	1-0	1-6	2-0	2-6	2-10	NP	NP	NP
		2 x 12	16-6	14-3	11-8	1-0	1-6	2-0	2-6	3-0	3-5	3-5	NP
	Redwood <sup>f</sup> Western cedars <sup>f</sup> Ponderosa pine <sup>f</sup> Red pine <sup>f</sup>	2 x 6	7-9	7-0	6-2	1-0	1-4	NP	NP	NP	NP	NP	NP
		2 x 8	10-2	9-3	7-11	1-0	1-6	2-0	1-11	NP	NP	NP	NP
		2 x 10	13-0	11-9	9-7	1-0	1-6	2-0	2-6	2-7	NP	NP	NP
		2 x 12	15-9	13-8	11-2	1-0	1-6	2-0	2-6	3-0	3-2	NP	NP

(continued)

**TABLE R507.6—continued  
MAXIMUM DECK JOIST SPANS**

LOAD <sup>a</sup> (psf)	JOIST SPECIES <sup>b</sup>	JOIST SIZE	ALLOWABLE JOIST SPAN <sup>b, c</sup> (feet-inches)			MAXIMUM CANTILEVER <sup>d, f</sup> (feet-inches)							
			Joist spacing (inches)			Joist back span <sup>g</sup> (feet)							
			12	16	24	4	6	8	10	12	14	16	18
70 ground snow load	Southern pine	2 × 6	8-3	7-6	6-5	1-0	1-6	1-5	NP	NP	NP	NP	NP
		2 × 8	10-10	9-10	8-2	1-0	1-6	2-0	2-2	NP	NP	NP	NP
		2 × 10	13-9	11-11	9-9	1-0	1-6	2-0	2-6	2-9	NP	NP	NP
		2 × 12	16-2	14-0	11-5	1-0	1-6	2-0	2-6	3-0	3-5	3-5	NP
	Douglas fir-larch <sup>e</sup> Hem-fir <sup>e</sup> Spruce-pine-fir <sup>e</sup>	2 × 6	7-11	7-1	5-9	1-0	1-6	NP	NP	NP	NP	NP	NP
		2 × 8	10-5	9-5	7-8	1-0	1-6	2-0	2-1	NP	NP	NP	NP
		2 × 10	13-3	11-6	9-5	1-0	1-6	2-0	2-6	2-8	NP	NP	NP
		2 × 12	15-5	13-4	10-11	1-0	1-6	2-0	2-6	3-0	3-3	NP	NP
	Redwood <sup>f</sup> Western cedars <sup>f</sup> Ponderosa pine <sup>f</sup> Red pine <sup>f</sup>	2 × 6	7-4	6-8	5-10	1-0	1-4	NP	NP	NP	NP	NP	NP
		2 × 8	9-8	8-10	7-4	1-0	1-6	1-11	NP	NP	NP	NP	NP
		2 × 10	12-4	11-0	9-0	1-0	1-6	2-0	2-6	2-6	NP	NP	NP
		2 × 12	14-9	12-9	10-5	1-0	1-6	2-0	2-6	3-0	3-0	NP	NP

For SI: 1 inch = 25.4 mm, 1 foot = 304.8 mm, 1 pound per square foot = 0.0479 kPa, 1 pound = 0.454 kg.

NP = Not Permitted.

- a. Dead load = 10 psf. Snow load not assumed to be concurrent with live load.
- b. No. 2 grade, wet service factor included.
- c.  $L/\Delta = 360$  at main span.
- d.  $L/\Delta = 180$  at cantilever with a 220-pound point load applied to end.
- e. Includes incising factor.
- f. Incising factor not included.
- g. Interpolation allowed. Extrapolation is not allowed.

**TABLE R507.7  
MAXIMUM JOIST SPACING FOR WOOD DECKING**

DECKING MATERIAL TYPE AND NOMINAL SIZE	DECKING PERPENDICULAR TO JOIST		DECKING DIAGONAL TO JOIST <sup>a</sup>	
	Single span <sup>c</sup>	Multiple span <sup>c</sup>	Single span <sup>c</sup>	Multiple span <sup>c</sup>
	Maximum on-center joist spacing (inches)			
1 1/4-inch-thick wood <sup>b</sup>	12	16	8	12
2-inch-thick wood	24	24	18	24

For SI: 1 inch = 25.4 mm, 1 foot = 304.8 mm, 1 degree = 0.01745 rad.

- a. Maximum angle of 45 degrees from perpendicular for wood deck boards.
- b. Other maximum span provided by an accredited lumber grading or inspection agency also allowed.
- c. Individual wood deck boards supported by two joists shall be considered single span and three or more joists shall be considered multiple span.

**R507.9.1.3 Ledger to band joist details.** Fasteners used in deck ledger connections in accordance with Table R507.9.1.3(1) shall be hot-dipped galvanized or stainless steel and shall be installed in accordance with Table R507.9.1.3(2) and Figures R507.9.1.3(1) and R507.9.1.3(2).

**R507.9.1.4 Alternate ledger details.** Alternate framing configurations supporting a ledger constructed to meet the load requirements of Section R301.5 shall be permitted.

**TABLE R507.9.1.3(1)  
DECK LEDGER CONNECTION TO BAND JOIST**

LOAD <sup>c</sup> (psf)	JOIST SPAN <sup>a</sup> (feet)	ON-CENTER SPACING OF FASTENERS <sup>b</sup> (inches)		
		1/2-inch diameter lag screw with 1/2-inch maximum sheathing <sup>d, e</sup>	1/2-inch diameter bolt with 1/2-inch maximum sheathing <sup>e</sup>	1/2-inch diameter bolt with 1-inch maximum sheathing <sup>f</sup>
40 live load	6	30	36	36
	8	23	36	36
	10	18	34	29
	12	15	29	24
	14	13	24	21
	16	11	21	18
	18	10	19	16
50 ground snow load	6	29	36	36
	8	22	36	35
	10	17	33	28
	12	14	27	23
	14	12	23	20
	16	11	20	17
	18	9	18	15
60 ground snow load	6	25	36	36
	8	18	35	30
	10	15	28	24
	12	12	23	20
	14	10	20	17
	16	9	17	15
	18	8	15	13
70 ground snow load	6	22	36	35
	8	16	31	26
	10	13	25	21
	12	11	20	17
	14	9	17	15
	16	8	15	13
	18	7	13	11

For SI: 1 inch = 25.4 mm, 1 foot = 304.8 mm, 1 pound per square foot = 0.0479 kPa.

- a. Interpolation permitted. Extrapolation is not permitted.
- b. Ledgers shall be flashed in accordance with Section R703.4 to prevent water from contacting the house band joist.
- c. Dead Load = 10 psf. Snow load shall not be assumed to act concurrently with live load.
- d. The tip of the lag screw shall fully extend beyond the inside face of the band joist.
- e. Sheathing shall be wood structural panel or solid sawn lumber.
- f. Sheathing shall be permitted to be wood structural panel, gypsum board, fiberboard, lumber or foam sheathing. Up to 1/2-inch thickness of stacked washers shall be permitted to substitute for up to 1/2 inch of allowable sheathing thickness where combined with wood structural panel or lumber sheathing.

**TABLE R507.9.1.3(2)**  
**PLACEMENT OF LAG SCREWS AND BOLTS IN DECK LEDGERS AND BAND JOISTS**

MINIMUM END AND EDGE DISTANCES AND SPACING BETWEEN ROWS				
	TOP EDGE	BOTTOM EDGE	ENDS	ROW SPACING
Ledger <sup>a</sup>	2 inches <sup>d</sup>	$\frac{3}{4}$ inch	2 inches <sup>b</sup>	$1\frac{5}{8}$ inches <sup>b</sup>
Band Joist <sup>c</sup>	$\frac{3}{4}$ inch	2 inches	2 inches <sup>b</sup>	$1\frac{5}{8}$ inches <sup>b</sup>

For SI: 1 inch = 25.4 mm.

- a. Lag screws or bolts shall be staggered from the top to the bottom along the horizontal run of the deck ledger in accordance with Figure R507.9.1.3(1).
- b. Maximum 5 inches.
- c. For engineered rim joists, the manufacturer's recommendations shall govern.
- d. The minimum distance from bottom row of lag screws or bolts to the top edge of the ledger shall be in accordance with Figure R507.9.1.3(1).

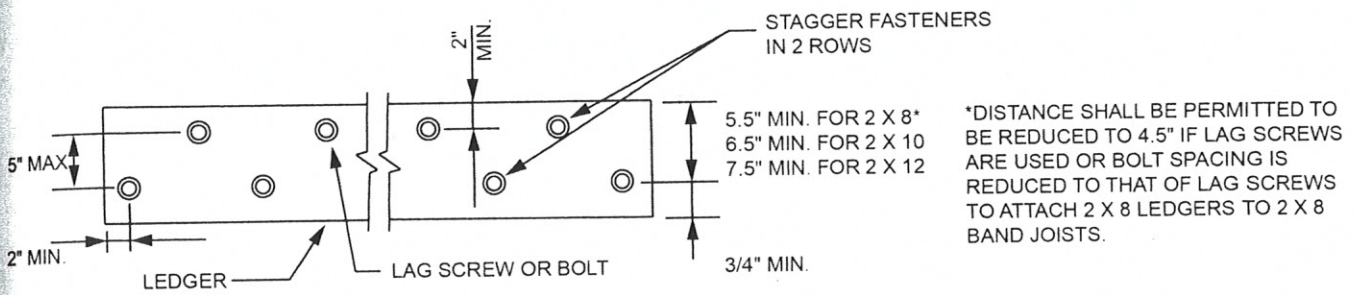

For SI: 1 inch = 25.4 mm.

**FIGURE R507.9.1.3(1)**  
**PLACEMENT OF LAG SCREWS AND BOLTS IN LEDGERS**

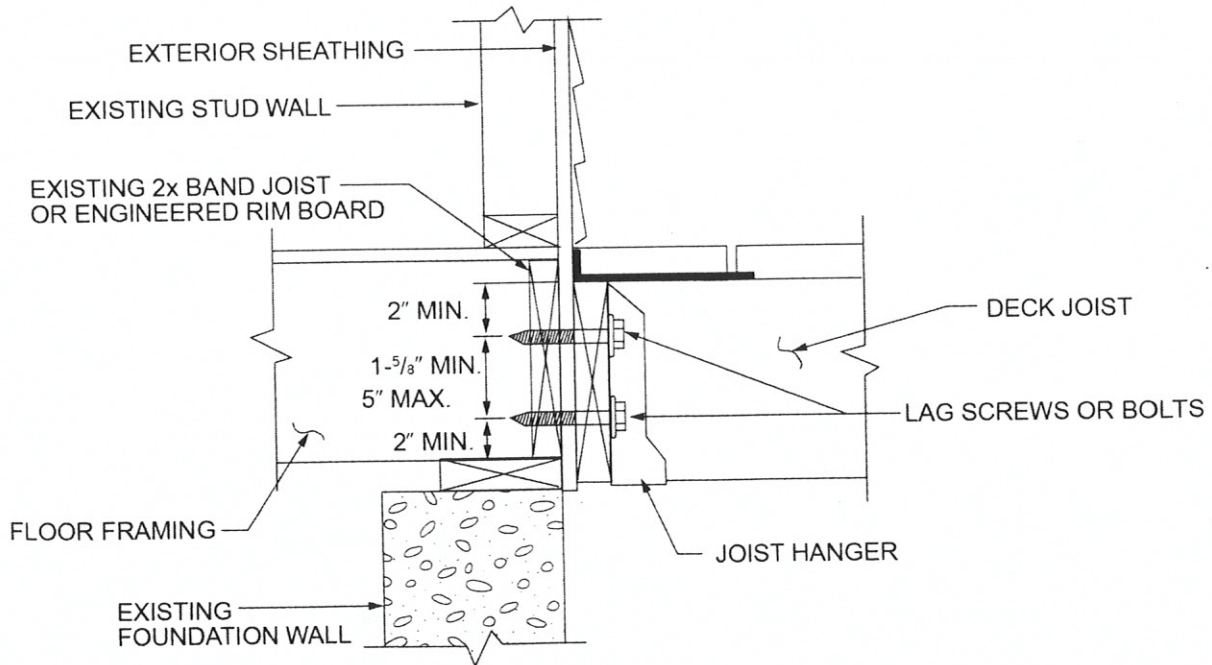

For SI: 1 inch = 25.4 mm.

**FIGURE R507.9.1.3(2)**  
**PLACEMENT OF LAG SCREWS AND BOLTS IN BAND JOISTS**

**R507.9.2 Lateral connection.** Lateral loads shall be transferred to the ground or to a structure capable of transmitting them to the ground. Where the lateral load connection is provided in accordance with Figure R507.9.2(1), hold-down tension devices shall be installed in not less than two locations per deck, within 24 inches (610 mm) of each end of the deck. Each device shall have

an allowable stress design capacity of not less than 1,500 pounds (6672 N). Where the lateral load connections are provided in accordance with Figure R507.9.2(2), the hold-down tension devices shall be installed in not less than four locations per deck, and each device shall have an allowable stress design capacity of not less than 750 pounds (3336 N).

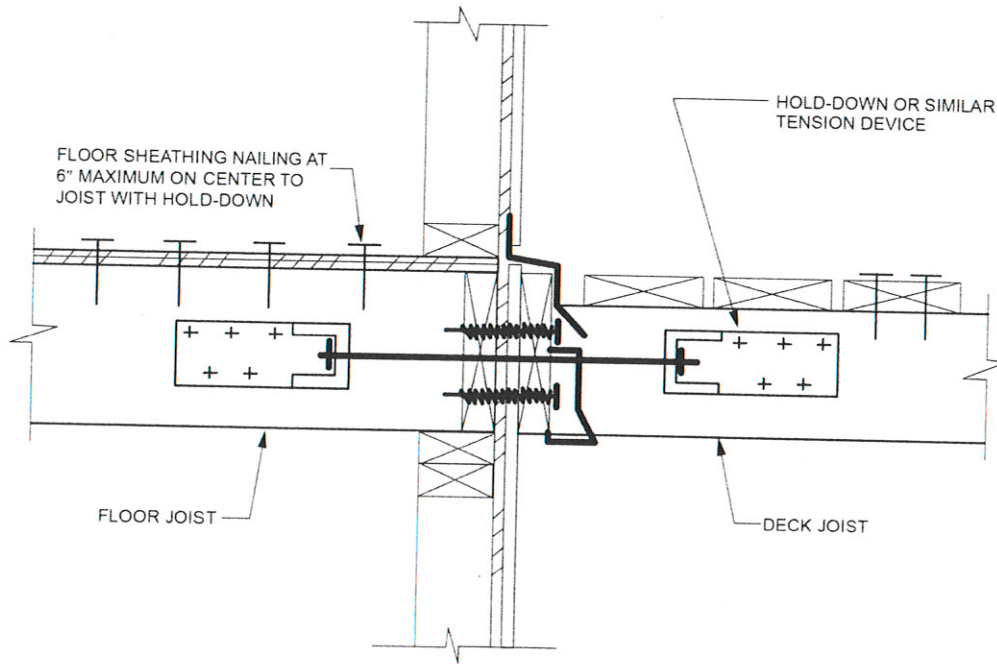

For SI: 1 inch = 25.4 mm.

**FIGURE R507.9.2(1)**  
**DECK ATTACHMENT FOR LATERAL LOADS**

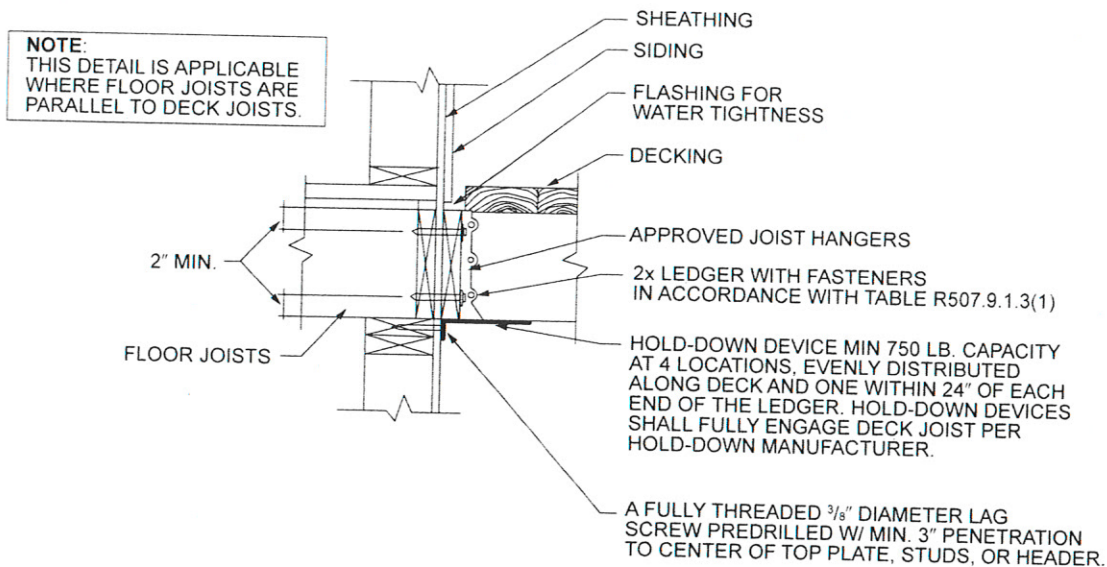

For SI: 1 inch = 25.4 mm, 1 foot = 304.8 mm.

**FIGURE R507.9.2(2)**  
**DECK ATTACHMENT FOR LATERAL LOADS**

R507 meet section R: su fe: th

R 4 k b R g R F d e

**R507.10 Exterior guards.** *Guards* shall be constructed to meet the requirements of Sections R301.5 and R312, and this section.

**R507.10.1 Support of guards.** Where *guards* are supported on deck framing, *guard* loads shall be transferred to the deck framing with a continuous load path to the deck joists.

**R507.10.1.1 Guards supported by side of deck framing.** Where *guards* are connected to the interior or exterior side of a deck joist or beam, the joist or beam shall be connected to the adjacent joists to prevent rotation of the joist or beam. Connections relying only on fasteners in end grain withdrawal are not permitted.

**R507.10.1.2 Guards supported on top of deck framing.** Where *guards* are mounted on top of the decking, the *guards* shall be connected to the deck framing or blocking and installed in accordance with manufacturer's instructions to transfer the *guard* loads to the adjacent joists.

**R507.10.2 Wood posts at deck guards.** Where 4-inch by 4-inch (102 mm by 102 mm) wood posts support guard loads applied to the top of the guard, such posts shall not be notched at the connection to the supporting structure.

**R507.10.3 Plastic composite guards.** *Plastic composite guards* shall comply with the provisions of Section R507.2.2.

**R507.10.4 Other guards.** Other *guards* shall be in accordance with either manufacturer's instructions or accepted engineering principles.

