

---

**Anderson County Technical Specification**  
**WQ-09: LEVEL SPREADERS**

---

**1.0 Level Spreaders**

**1.1 Description**

Use Level Spreaders to disperse concentrated runoff uniformly over ground surfaces as sheet flow. Use Level Spreaders for peak design flow rates up to 10 cubic feet per second (cfs). Level Spreaders are constructed at a zero percent grade across a slope consisting of a permanent weir structure used to disperse or spread concentrated flow thinly over a Vegetated Filter Area. The main purpose is to spread potentially erosive concentrated flow over a wide area so that erosion does not occur at the outlet. Added benefits include increased infiltration and increased pollutant and nutrient removal.

Level Spreader components include:

- High Flow Splitter
- Forebay
- Level Spreader Swale
- Underdrain
- Level Spreader Lip
- Vegetated Filter Area
- Bypass Conveyance Channel

Use Level Spreaders to convey runoff from impervious surfaces and pipe outfalls, uniformly onto vegetated filter areas or onto stream buffers. Level Spreaders are applicable:

- At outlets for diversion structures.
- At outlets into riparian buffers.
- Where uniform, sheet flow can be achieved down slope of the Level Spreaders.
- In areas requiring a Vegetated Filter Area to treat runoff.
- As a segment of a stormwater BMP treatment series.
- Where runoff from an impervious surface is uneven and/or runoff is released as concentrated flow, such as through curb cuts or slope drains.

Do not use Level Spreaders:

- Where discharge slopes exceed 6% for wooded/forested filter areas or 8% for thick ground cover/grass filter areas.
- Where there is a draw located within the Vegetated Filter Area down slope of a proposed level spreader that will re-concentrate flow.
- Where the runoff water will re-concentrate after release from the level spreader before reaching an outlet designed for concentrated flow or receiving water body.
- Where there will be traffic over the level spreader.

**1.2 Design**

Depending on the site layout and flows, Level Spreader components may include a high flow splitter, and a forebay system. Level Spreaders not discharging to a specific stormwater BMP or designed stormwater conveyance system must discharge to a Vegetated Filter Area.

Use Level Spreaders as a stand-alone BMP, or in a series to treat stormwater runoff. Flow, slope, site constraints, and design considerations dictate which method is used.

For Stream Buffer or water quality control applications, design the Level Spreader to manage the peak flow from the 2-year, 24-hour storm. Ensure the runoff from the Level Spreader discharges to a 35-foot minimum vegetated filter area width.

Ensure the Level Spreader design accounts for runoff at ultimate build-out, including off-site drainage.

Flows to the Level Spreader must not exceed 10 cfs in any application. Bypass all flows greater than 10 cfs. Bypass must be able to safely convey the 100-year, 24-hour storm flows to the receiving water body through a stable bypass conveyance.

Level Spreader dimensions are derived from the design flow (cfs). Table 1 shows the minimum depth and minimum length of the level spreader lip based on design flows.

**Table 1: Level Spreader Dimensions**

Design Flow (cfs)	Minimum Level Spreader Swale Depth (ft)	Minimum Level Spreader Swale Top Width (ft)	Level Spreader Lip Length (ft)	Minimum Lip Length (ft)
0-10	1.0	3.0	10 feet per cfs	30

Design the Level Spreader Swale to handle the expected peak flow rates with a minimum bottom width of 1-foot with side slopes of 1H:1V or flatter and a minimum top width of 3 feet. The Level Spreader Swale has a maximum grade of 0.5%. Tie the ends of the level spreader into higher ground to prevent flow around the spreader.

A Forebay is used to collect the runoff before the water is sent to the Level Spreader Swale. Design the forebay to be 0.5% of the contributing impervious surface area. The depth is 3 feet at the deepest point, and decrease to 1 foot as the forebay approaches the level spreader swale.

### 1.3 Components

#### 1.3.1 Forebay

Use a Forebay for the preliminary treatment of stormwater allowing sediment to settle out. Excavate the Forebay as a bowl-shaped feature to slow the influent before it reaches the Level Spreader Lip. Reinforce the Forebay with turf reinforcement matting (TRM) or Class A riprap.

#### 1.3.2 Level Spreader Swale

Immediately upslope of the Level Spreader Lip, stormwater is discharged into the Level Spreader Swale (which is terminated at either end to ensure flow goes over the level spreader lip). Within the Level Spreader Swale, water rises and falls evenly over the Level Spreader Lip, distributing flow evenly over its length. Whenever practical, convey stormwater to the level Spreader Swale parallel to the Level Spreader Lip to avoid short circuiting.

#### 1.3.2 Underdrain Pipe

Use underdrain pipe when soils are not capable of infiltrating water detained within the Forebay and Level Spreader Swale. Install an underdrain when the Level Spreader is installed on soil with an infiltration rate less than 2 in/hr. The underdrain drains the Forebay and Level Spreader Swale between storm events to provide capacity for the next storm event, allows the turf to dewater and minimizes mosquito risks. The underdrain discharges to the Stabilized Flow Bypass Conveyance Channel.

#### 1.3.3 Level Spreader Lip

Use a Level Spreader Lip made of a poured concrete weir set at a 0% grade. The Level Spreader Lip is the main body of the level spreader that receives water from the forebay, directly from a BMP, or directly from a pipe outlet. Construct the lip so it is level along the entire length. Ensure the lip is a minimum of 6 inches higher than the existing ground on the downslope side and anchored into the ground with an appropriately sized concrete footer. Install earthen or concrete berms at each end of the Level Spreader to prevent bypass of runoff.

The Level Spreader must be straight or convex in plan view. Ensure Level Spreaders are not concave in plan view because this concentrates flow downslope of the Level Spreader. To minimize the grading needed to install the Level Spreader, ensure it is placed so that it is parallel to contour lines.

#### 1.3.4 Turf Reinforcement Matting (TRMs)

The Level Spreader Swale and Forebay may be stabilized with TRMs.

#### 1.3.5 Non-woven Geotextile

Place and anchor a Class 2, Type C nonwoven geotextile on the downslope side of the Level Spreader Lip a minimum of 3 feet and place a 3- to 4-inch layer of #57 stone on top of the geotextile to minimize erosion.

#### 1.3.6 Vegetated Filter Area

After passing over the Level Spreader Lip, stormwater enters a Vegetated Filter Area. The slope of the Vegetated Filter Area should not exceed 8%. The minimum width of the Vegetated Filter Area is **35 feet**.

For Stream Class Type 2 the Managed Use Zone of the Permanent Water Quality Stream Buffer may be used as the Vegetated Filter Area when:

- The Managed Use Zone consists of an existing dense herbaceous buffer,
- The herbaceous buffer has an existing minimum ground cover of 70%,
- The area is validated by Anderson County during a field site visit, and
- In no cases, trees are cut in the Managed Use Zone to create the required vegetated filter area.

It is crucial that the slope and vegetation of the proposed natural herbaceous Vegetated Filter Area be surveyed in the field to ensure that the vegetation and slopes comply with requirements of this Specification.

Do not use Permanent Water Quality Stream Buffers as a Vegetated Filter Area if any natural draws or channels are present. If the buffer is herbaceous in nature but does not contain a thick stand of vegetation, then add additional plantings to stabilize the ground surface.

For an effective Vegetated Filter Area, it is essential to prepare the soils properly and plant and maintain a dense, vigorous stand of turfgrass Sod. Use Tall Fescue or Common Bermuda grass for Vegetated Filter Areas.

Vegetation must be established prior to receiving flow. A temporary stormwater diversion is necessary until the vegetation in the Vegetated Filter Area is stabilized. The Vegetated Filter Area must retain the capacity to pass flow without erosion. Since stable vegetation must be established in the Vegetated Filter Area before the Level Spreader can be put on-line, consider the time of year as construction may be limited to the growing season in order to ensure that a vegetated cover is established.

#### 1.3.7 Flow Bypass Conveyance Channel

Use a Flow Bypass splitter or diversion box to pass all excess flow around the Level Spreader and into a stabilized Flow Bypass Conveyance Channel. The Flow Bypass splitter must be capable of diverting all flows above the Level Spreader design event.

Use a TRM in place of riprap when possible to stabilize the Flow Bypass Conveyance Channel. Add check dams and energy dissipaters, as needed, to stabilize the Flow Bypass Conveyance Channel. When discharging to a receiving water body, design the discharge point of the Flow Bypass Conveyance Channel at a 30-degree angle downstream into the receiving waterway to minimize erosion and bank degradation. Discharge the Flow Bypass Conveyance Channel into a deep section of the stream when practicable and protect stream banks with a TRM or riprap at the discharge point. Other options include discharging to a velocity dissipater, a plunge pool, or a culvert. Site conditions and/or water quality requirements will guide design decisions for discharging bypass flow.

## **1.4 Construction Requirements**

Construct Level Spreaders on undisturbed soil whenever possible. If the use of fill is unavoidable, compact the fill material to 95% of standard proctor tests. Protect the Level Spreader and downstream Vegetated Filter Area from sediment and stormwater flows during construction. Ensure flows bypass the Vegetated Filter Area until vegetation is established. Avoid driving heavy equipment in the footprint of the Level Spreader. Remove excavated materials from the level spreader and forebay and dispose of them properly.

### **1.4.1 Site Preparation**

Before Level Spreader construction, verify that ground contours are parallel to the Level Spreader location, Vegetated Filter Area slopes are less than 8%, and no draws are located in the Vegetated Filter Area downstream of the Level Spreader. Use only sites with topography that allows a smooth transition from the Level Spreader Lip to the downstream Vegetated Filter Area. Avoid drops or irregular areas that allow water to re-concentrate and erode the Vegetated Filter Area, stream buffer, and possibly the receiving stream.

Ensure there is adequate access around the Level Spreader site to accommodate for post construction inspection and maintenance. Regular maintenance is required for the Level Spreader to function as designed.

### **1.4.2 Installation**

Install Level Spreaders with the following construction sequence when appropriate:

- Install Flow Bypass Conveyance Channel.
- Grade Vegetated Filter Area.
- Excavate Vegetated Filter Strip Swale and Underdrain Area.
- Install Concrete Level Spreader Lip.
- Install Underdrain.
- Install Leveled Spreader Swale.
- Install Forebay.
- Install Flow Bypass Device.

#### **1.4.2.1 Flow Bypass Conveyance Channel**

Install the flow bypass diversion box according to the design Plans. This structure is installed at the outlet of the watershed and splits flow between the Forebay and the Flow Bypass Conveyance Channel. Install the Flow Bypass Conveyance Channel and install stabilization measures as shown on the Plans. Direct all flows to the Flow Bypass Conveyance Channel until the Level Spreader and any associated vegetation is fully stabilized.

#### **1.4.2.2 Vegetated Filter Area**

Grade the Vegetated Filter Area (if required) to the design slope using a box blade or similar equipment. Avoid driving heavy equipment through the Vegetated Filter Area to prevent compaction.

Vegetated Filter Area soils must not be compacted. Loosen the soil by raking, tilling or using a field cultivator. After the Vegetated Filter Area soils have been loosened, add topsoil or compost. Add lime and fertilizer based on the results of a soil test. Establish a permanent stand of vegetation by Sodding.

#### 1.4.2.3 Excavation

Excavate the area for the Level Spreader Swale and Level Spreader Lip as shown on the Plans. Remove excavated materials and dispose of them properly.

#### 1.4.2.4 Level Spreader Lip

Install an appropriately sized concrete footer to stabilize the concrete Level Spreader Lip. Install a 1-foot wide cast in place concrete Level Spreader Lip at 0% grade. Ensure that the top of the forms are level.

Install the Level Spreader Lip a minimum of 6 inches higher than the existing downstream ground. Place and anchor a Class 2, Type C nonwoven geotextile on the downslope side of the Level Spreader Lip a minimum of 3 feet and place a 3 to 4-inch layer of #57 stone on top of the geotextile to minimize erosion.

#### 1.4.2.5 Underdrains

Install perforated pipe underdrains beneath the Forebay and Level Spreader Swale with a minimum diameter of 4-inches conforming to the requirements of *SCDOT Technical Specification Section 802, Pipe Underdrains* when the underlying soil has an infiltration rate less than 2 in/hr. Ensure the underdrain discharges to the Flow Bypass Conveyance Channel.

#### 1.4.2.6 Level Spreader Swale

The Level Spreader Swale is typically constructed from earth and is stabilized with turfgrass Sod TRMs, concrete, or lined with rip rap. Install the Level Spreader Swale with dimensions as shown on the design Plans. Tie the ends of the Level Spreader Swale into higher ground to prevent flow around the level spreader lip

Place topsoil in the excavated trench over the underdrain system, and Sod the swale. Sod is strongly preferred for the Level Spreader Swale. In urban applications, the Level Spreader Swale may be concrete. An advantage of a concrete channel is the relative ease in removing accumulated debris.

#### 1.4.2.7 Forebay

Construct a Forebay upstream of the Level Spreader Swale using a small excavator. Excavate the Forebay to the dimensions, side slopes, and elevations shown on the site Plans. The minimum depth of the Forebay ranges from 1 to 3 feet.

### 1.4.3 Inspection and Maintenance of Level Spreaders

Regular inspection and maintenance is critical to the effective operation of Level Spreaders. During the first year after construction, inspect Level Spreaders for proper distribution of flows and signs of erosion during and after all major rainfall events. After the first year, inspect Level Spreaders annually.

Summary of maintenance requirements:

- Maintain Level Spreaders annually and after all major storm events.
- Check the Level Spreader and downstream vegetated area for signs of erosion.
- Address erosion that is discovered in the vegetated area through the application of turf reinforcement matting (TRM) and through re-grading if necessary.
- Remove sediment and debris from the Forebay and from behind the Level Spreader Lip.

- Maintain the vegetation in the Forebay and around the Level Spreader to a height of approximately 3 to 6 inches.

Other required maintenance includes, but is not limited to:

- Mowing and trimming as needed.
- Replacing or replenishing vegetation and plants as needed.
- Removing trash and debris periodically as needed.
- Re-grading and re-seeding Level Spreader upslope edges and the forebay as a result of deposited sediment. (Depositing sediment may kill grass and change the level spreader elevation.)

#### 1.4.4 Acceptance

Obtain ENGINEER acceptance and approval for all Level Spreader installations.

### 1.5 References

Greenville County, SC, Technical Specification for WQ-13 Level Spreader, March 2020

North Carolina DENR Stormwater BMP Manual, March 9, 2010.

North Carolina Division of Water Quality, Level Spreader Design Guidance, January 1, 2007.

Natural Resources Conservation Service, Conservation Practice Standard for Level Spreader, January 1999.

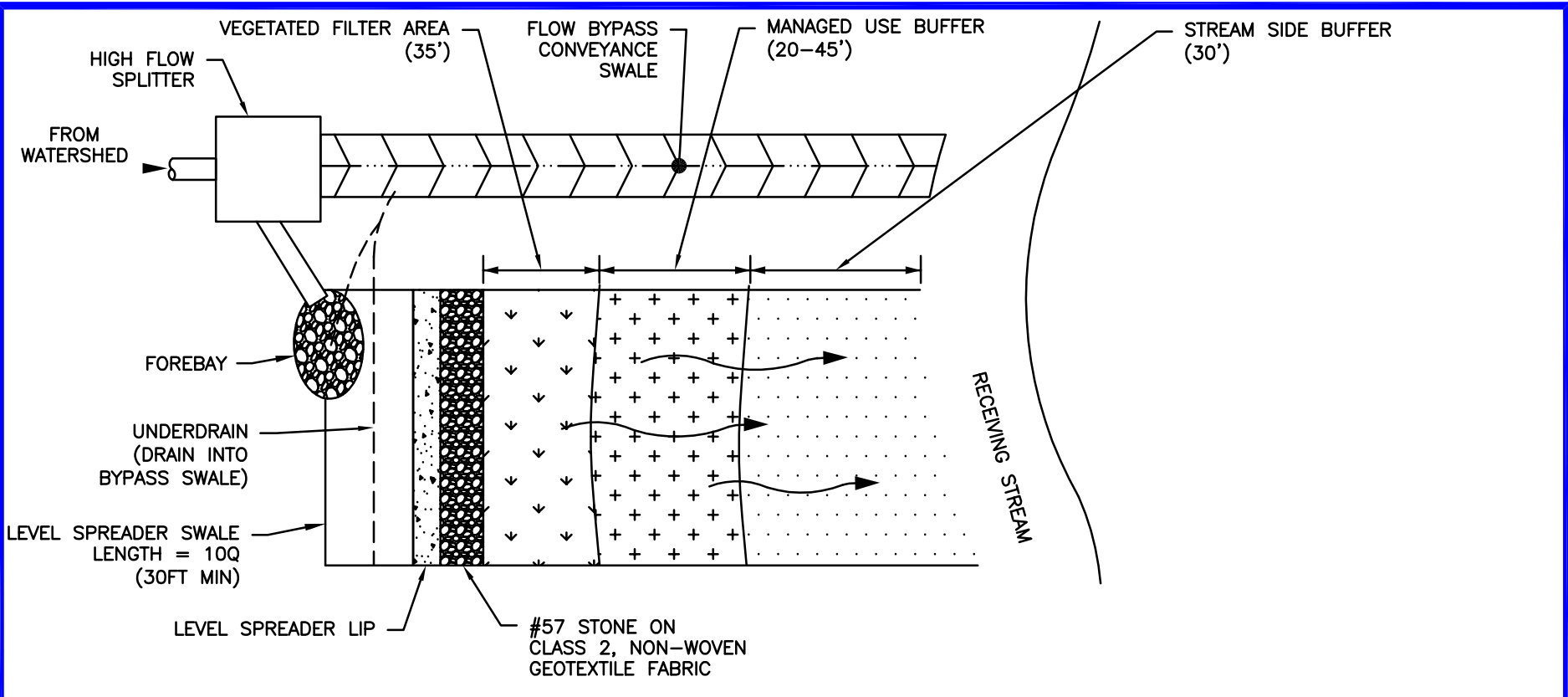

PLAN VIEW

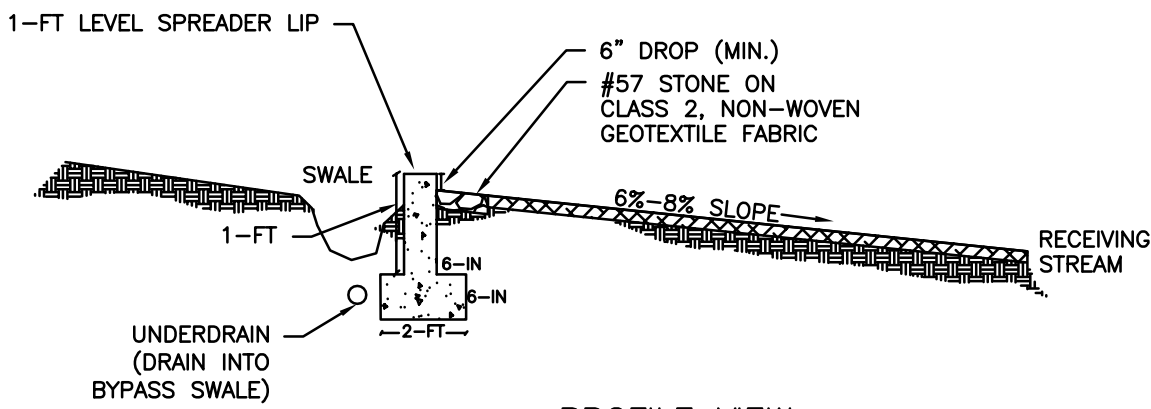

PROFILE VIEW

SCALE: NONE

Anderson County, SC	
WQ LEVEL SPREADER	
STANDARD DRAWING NO. WQ-09	
APPROVED BY: _____	AUGUST 2025 DATE
Anderson County, SC	

## LEVEL SPREADER MAINTENANCE AND RESPONSIBILITY AGREEMENT

The Permanent *Stormwater System Maintenance and Responsibility Agreement* requires adequate maintenance for stormwater management/Best Management Practices (BMP) facilities including Level Spreaders. Document Level Spreaders deficiencies during **annual** inspections. Complete any necessary repairs and/or preventive maintenance procedures in a timely manner to ensure proper functioning as Level Spreaders.

Important maintenance procedures:

- Immediately after the installation, water newly planted vegetation twice weekly as needed until the vegetation becomes established (typically six weeks).
- Ensure the grass cover is dense and healthy. Re-sod or re-seed if necessary to ensure a dense stand of grass.
- Maintain stable groundcover in the drainage area to reduce the sediment load.
- Two to three times per year, grass filter strips will be mowed and the clippings harvested to promote the growth of thick vegetation with optimum pollutant removal efficiency. Turf grass should not be cut shorter than 3 to 5 inches and may be allowed to grow as tall as 12 inches depending on the aesthetic requirements. Forested filter strips do not require this type of maintenance.
- Once a year, the soil will be aerated if necessary.
- Once a year, soil pH will be tested and lime will be added if necessary.
- Annually inspect the BMP to ensure proper function and effectiveness as a stormwater best management practice.

After vegetation is established, perform inspections once a quarter and after every storm event greater than 1.0 inch, and annually thereafter. Keep operation and maintenance records in a known location and make them available upon request.

Perform recommended maintenance activities as follows:

Required Maintenance	Frequency
Periodic pruning and weeding.	As needed
Remove trash and debris.	As needed
Inspect inflow points for clogging. Remove any sediment.	Every 6-months
Repair eroded areas. Re-seed or sod as necessary.	Every 6-months
Inspect trees and shrubs to evaluate their health.	Every 6-months
Remove and replace dead or severely diseased vegetation.	Every 6-months
Removal of evasive vegetation.	Every 6-months
Nutrient and pesticide management.	Annual, or as needed
Water vegetation, shrubs, and trees.	Every 6-months

Perform trouble shooting activities as follows:

Field Condition	Common Solutions
Trash/ Debris is present	Remove trash/ debris
Water is channelizing and causing erosion.	Re-grade if necessary to smooth it over and Provide additional erosion protection as needed such as erosion control blankets and turf reinforcement matting to prevent future erosion problems.
Too much sediment has accumulated.	Remove accumulated sediment to recover capacity. A sediment forebay may be required. Remove sediment that exceeds 2 inches on more than 10% of the vegetated treatment area, or anywhere that it is interfering with performance.
The flow control device is clogged or damaged	Unclog and properly dispose of any sediment off site. Make any necessary repairs or replace device if necessary.
Grass is too long or too short.	Maintain grass at a height of approximately three to six inches.
Plants are desiccated, dead, diseased or dying	Determine the source of the problem (soils, hydrology, disease, etc.). Remedy the problem and replace plants. Provide a one-time fertilizer application. Provide additional irrigation and fertilizer as needed.
Nuisance vegetation is choking out desirable species	Remove vegetation by hand if possible. If pesticide is used, do not allow it to get into the receiving water (stream, pond, etc.).